

Multiprofile Bits

8/956.8



Create endless profiles with CMT multiprofile bits. Simply adjust the height of the bit to create classic profiles in one single pass, or make more complex decorative effects in multiple passes. The bits super-strength steel body can withstand long-lasting cutting operations, and the micrograin carbide tips remain sharp longer for superior performance. In addition these bits feature non-stick PTFE coating and anti-kickback design. To be used on tables equipped with a fence.

SAFETY TIPS: to make small mouldings as shown below, cut the profile from very wide stock. Remove the excess material and work on the bigger piece to give you easier control. Keep hands far from the bit when working.

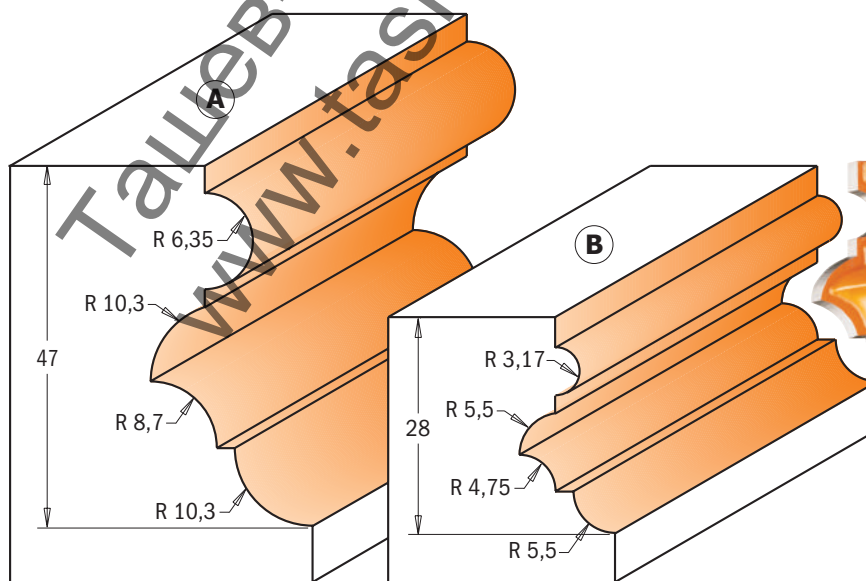
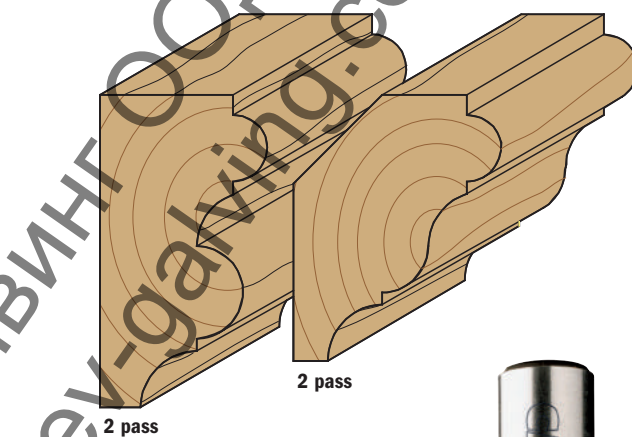
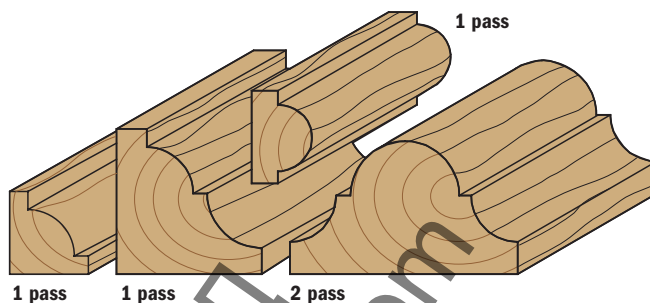
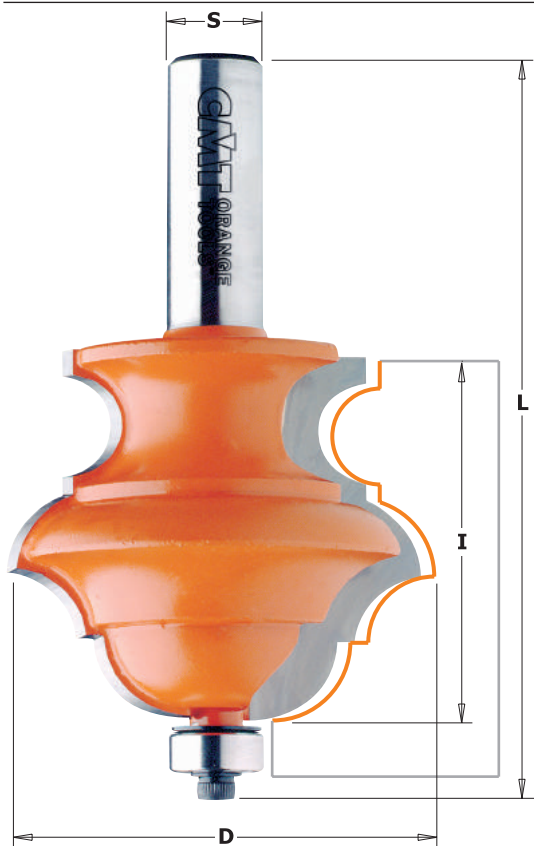

Drawings are 1:1 scale



PROFILE	D mm	I mm	L mm		ORDER NO. S=Ø12mm	ORDER NO. S=Ø12,7mm	Spare parts			
A	55,6	47	96,4	5	956.802.11	856.802.11				
B	38,1	28	77,5	10	956.801.11	856.801.11	990.423.00	791.003.00	990.058.00	991.057.00